

ECO PHYSICS CLD 822 S hr

Application examples

- Burners and boilers
- Manufacturers of gas turbines
- Certification and calibration authorities
- DeNO_x plants
- Refining of fuels and lubricants
- Tobacco industry
- Research and development



The solution for simultaneously measured NO and NO_x has got a name: CLD 822 S hr. The heated inlet copes with hot and humid gas samples – no gas cooler required!



A fascinating technology.

The analyzer is not only a state-of-the-art product in terms of precision and reliability. Its technological base also sets the trend for others. The integrated hot tubing (h) allows the direct measurement of hot and moist gases. An external preconditioning of the sample gas is not required. Naturally occurring pressure variations in the sample flow are balanced out by means of an electronic and mechanical bypass system (r).

Many options can be integrated without any problem to satisfy the need for nonstandardized applications. The advantage of compact design: the CLD 822 S hr includes everything inside the case – even the vacuum pump and the ozone scrubber.

Two instead of one.

The CLD 822 S hr nitrogen oxide analyzer is optimized for its use in systems which require reliable NO₂ measurements or the control of two sample gases in parallel.

The concept with two parallel reaction chambers allows the simultaneous measurement of NO and NO_x in order to generate the precise value of NO₂.



The CLD 822 S hr with slides is perfectly prepared for rack mounting

The analyzer is capable of coping with two separate measurement tasks. This may include the task of comparing the values at the inlet and the outlet of a process or the direct comparison of two independent samples. The analyzer simply requires a dual inlet feature option (d) and one additional converter.

User-friendliness is a top priority.

The analyzer can be operated by means of the integrated keypad or remotely from a personal computer. The clear layout of the menu structure guides the user and enables him to take advantage of all analyzer functions with simple commands. Integrating the analyzer in larger systems is possible by including runners in the standard chassis design.

- Four freely selectable measurement ranges [with option (d) two per channel]
- Choice between several types and numbers of converters from 0 to 2 according to the application
- Error messages coded and in full text
- Rapid system integration
- Virtually maintenance-free even in continuous operation



CLD 822 S hr

Specifications

Measuring ranges	four freely selectable ranges from 5–5000 ppm, with option d two per channel	Supply voltage	100 – 230 V / 50 – 60 Hz
Min. detectable concentration	0.25 ppm*	Interface	RS 232
Noise at zero point (1σ)	0.125 ppm*	Analog output	4–20 mA into 500 Ω max.; 0–1 V; 0–10 V
Lagtime	< 1 sec	Dimensions	height: 133 mm (5 1/4") width: 450 mm (19") with moulding: 495 mm depth: 545 mm
Rise time (0–90%)	< 1 sec	Weight	26 kg
Temperature range	5–40 °C	Delivery includes	CLD 822 S hr analyzer, power cable, analog signal cable, manual
Humidity tolerance	5–95% rel. h (noncondensing, ambient air and sample gas)	Standard	CLD 822 S hr steel converter, hot tubing and electromechanical pressure regulation
Quenching (with gas cooler)	for H ₂ O: < 1.5% of meas. value for CO ₂ : < 0.3%/vol.-% CO ₂	Options	M metal converter d dual sample gas inlet MM d dual channel NO _x /NO _x
Sample flow rate	1.2 l/min (0.1 l/min without option r)	<i>* depending on filter setting</i>	
Input pressure	600–1200 mbar abs. (without option r to be externally stabilized within ±3 mbar)	<i>ECO PHYSICS reserves the right to change these specifications without notice.</i>	
Dry air use for O₃ generator	internally generated (no external supply gas required)		
Power required	400 VA (incl. membrane pump and ozone scrubber)		

Flow diagram

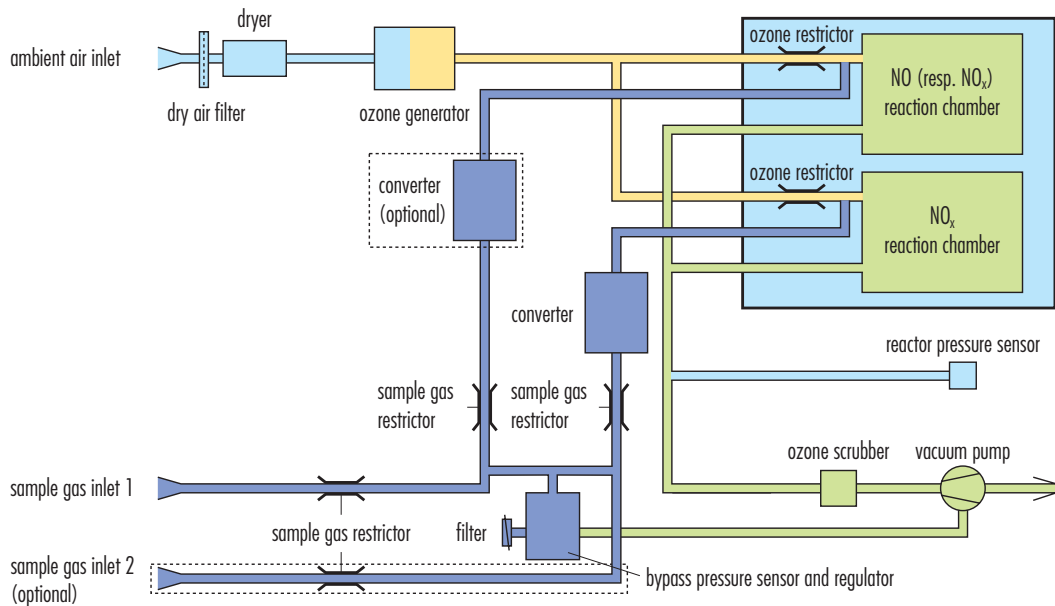

ECO PHYSICS

ECO PHYSICS, INC. 3915 Research Park Dr. A-3 Ann Arbor, MI 48108 tel. 734-998-1600 fax 734-998-1180
Email: sales@ecophysics-us.com Website: http://www.ecophysics-us.com