

# ECO PHYSICS CLD 63

## Application examples

- Compact design
- Internal ozone generator and scrubber
- Metal or steel converter for NO<sub>x</sub> detection
- Four freely selectable measurement ranges
- Operation and control via keypad or personal computer
- Mobile DC operation

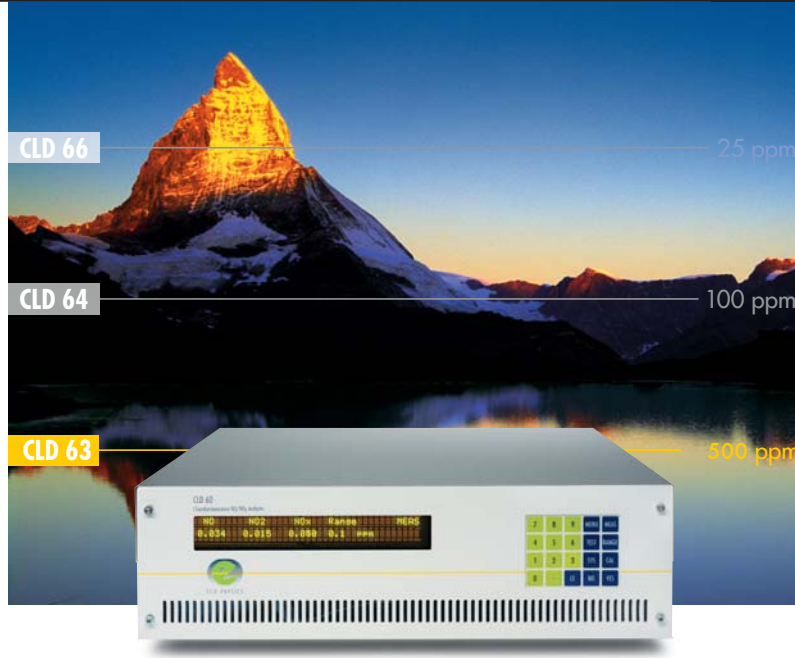

- Stack emission measurement
- Operation of boiler and burner
- Waste incineration plants
- Power-generating turbines
- Gas turbine installations

**The new CLD 63 nitrogen oxide analyzer is the economical solution for the continuous measurement of NO and NO<sub>x</sub> concentrations in fixed or mobile applications.**



*Stack emissions.*

### We help you to keep the limits

For years ECO PHYSICS has been one of the leading firms in pollutant measurement. Our analyzers come into use wherever concentrations of nitrogen oxide compounds have to be measured.

Threshold value ordinances, as well as quality directives, only make sense if they can be effectively monitored.

This is where our analyzers come into play. Either integrated into entire production processes and systems, or as stand-alone devices, they continuously deliver the exact NO and NO<sub>x</sub> values you require. The design of the instrument is optimized for rack mount and stand-alone applications.

### Economical solution

The CLD 63 is the ideal instrument for series checks of NO and total NO<sub>x</sub> in fixed or mobile stations. This single-channel analyzer is designed for all applications with an existing gas preconditioning unit to ensure quality control as well as keeping to threshold values.

Total NO<sub>x</sub> is measured by metal or an optional steel converter.

### User-friendliness

The development of an ECO PHYSICS analyzer always includes full user comfort. The user can adapt the operation according to his needs and applications by selection of predefined settings via the keypad and remotely from a PC.

Warning and error messages are displayed coded and in full text. The analyzer guides the user step by step to return to normal operation.

Maintenance simply means annual replacement of filters and membranes besides the consumables required by special sampling conditions.

### Easy calibration

Calibration is quickly and automatically carried out. This extremely useful feature eliminates the potential risk of erroneous calibrations.

### Compact and modular design

The CLD 63 is the most compact unit of its class. Thanks to the totally modular layout and integrated ozone generator and scrubber it is designed for a multitude of applications.



*Burner operation.*



*Waste incineration plants.*

# CLD 63

## Specifications

<i>Measuring ranges</i>	four freely selectable ranges from 0.5 to 500 ppm	<i>Dimensions</i>	height: 133 mm (5 <sup>1</sup> / <sub>4</sub> " width: 430 mm (17" depth: 455 mm (18"
<i>Min. detectable concentration</i>	0.05 ppm	<i>Weight</i>	13 kg (29 lb) without pump
<i>Noise at zero point (1<math>\sigma</math>)</i>	0.02 ppm	<i>Delivery includes</i>	CLD 63 analyzer, external power supply, power cable, vacuum pump, operator's manual
<i>Lagtime</i>	<1 sec	<i>Standard</i>	CLD 63 NO/NO <sub>x</sub> analyzer with internal metal converter
<i>Rise time (0-90%)</i>	<3 sec	<i>Options</i>	S steel converter IO analog I/O interface (dual output) L LAN DC 24 V operation incl. DC vacuum pump R rack mount slides F inlet filter
<i>Temperature range</i>	5-40 °C		
<i>Humidity tolerance</i>	5-95% rel. h (non-condensing, ambient air and sample gas)		
<i>Sample flow rate</i>	0.3 l/min		
<i>Input pressure</i>	ambient		
<i>Dry air use for O<sub>3</sub> generator</i>	internally generated (no external supply gas required)		
<i>Power required</i>	250 VA, external membrane pump 250 VA		
<i>Supply voltage</i>	100-230 V/50-60 Hz, external power supply		
<i>Interface</i>	RS 232C; LAN (optional)		
<i>Analog output (optional)</i>	4-20 mA into 500 $\Omega$ max.; 0-1 V; 0-10 V		

ECO PHYSICS reserves the right to change these specifications without notice.

## Flow diagram

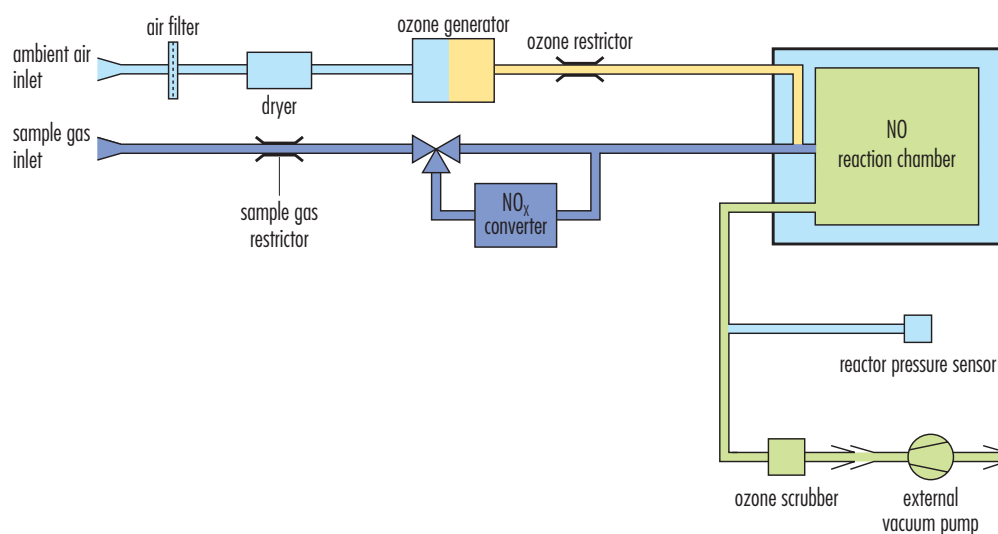

ECO PHYSICS

ECO PHYSICS INC. . 3915 Research Park Drive, Suite A-3 . ANN ARBOR, MI 48108-2200 . USA . Phone: (734) 998-1600 . Fax: (734) 998-1180

sales@ecophysics-us.com . [www.ecophysics-us.com](http://www.ecophysics-us.com)