

ECO PHYSICS CLD 824 MM dr

Application examples

Burners in parallel
Energy production
Quality control in production lines
DeNO _x devices
Petrochemical plants
Tobacco industry



The solution for measuring simultaneously NO_x in sample gases from different sources has got a name: CLD 824 MM dr. This means two CLD NO_x analyzers in one case!



Two instead of one.

The CLD 824 MM dr nitrogen oxide analyzer is optimized for its use in systems which include gas sampling equipment to measure different samples in parallel.

The concept of two parallel sample paths, each equipped with an NO₂ converter and a separate reaction chamber, makes this analyzer capable to cope with two separate measurement tasks.

This may include the need to compare the values at the inlet and the outlet of a process or the direct comparison of two independent samples.

A fascinating technology.

The analyzer is not only a state-of-the-art product in terms of precision and reliability. Its technological base also sets the trend for others. Naturally occurring pressure variations in the sample flow are balanced out by means of an electronic and mechanical bypass system (r). This module is not required in systems with external sample pressure regulations.

The integration of the optional hot tubing (h) allows the direct application of hot and moist gases without external preconditioning of the sample gases.



All external connections of the CLD 824 MM dr are hidden but easily accessible from the rear

Many options can be integrated without any problem to satisfy the need for nonstandardized applications. The advantage of compact design: the CLD 824 MM dr includes everything inside the case – even the vacuum pump and the ozone scrubber.

- Two freely selectable measurement ranges per channel
- Choice between several types and numbers of converters from 0 to 2 according to the application
- Error messages coded and in full text
- Rapid system integration
- Virtually maintenance-free even in continuous operation



User-friendliness is a top priority.

The analyzer can be operated by means of the integrated keypad or remotely from a personal computer. The clear layout of the menu structure guides the user and enables him to take advantage of all analyzer functions with simple commands. Integrating the analyzer in larger systems is possible by including runners in the standard chassis design.

Two independent measuring ranges

CLD 824 MM dr

Specifications

<i>Measuring ranges</i>	two user-defined ranges per channel: 0.5–500 ppm respectively 5–5000 ppm	<i>Power required</i>	400 VA (incl. membrane pump and ozone scrubber)
<i>Min. detectable concentration</i>	0.025 ppm resp. 0.25 ppm*	<i>Supply voltage</i>	90–250 V/50–60 Hz
<i>Noise at zero point (1σ)</i>	0.012 ppm resp. 0.125 ppm*	<i>Interface</i>	RS 232
<i>Lagtime</i>	< 1 sec	<i>Analog output</i>	4–20 mA into 500 Ω max.; 0–1 V; 0–10 V
<i>Rise time (0–90%)</i>	< 1 sec	<i>Dimensions</i>	height: 133 mm (5 $\frac{1}{4}$ "") width: 450 mm (19") with moulding: 495 mm depth: 545 mm
<i>Temperature range</i>	5–40 °C	<i>Weight</i>	26 kg
<i>Humidity tolerance</i>	5–95% rel. h (noncondensing, ambient air and sample gas)	<i>Delivery includes</i>	CLD 824 MM dr analyzer, power cable, analog signal cable, manual
<i>Quenching (with gas cooler)</i>	for H ₂ O: < 4% resp. 1.5% of meas. value for CO ₂ : < 1% resp. 0.3% per vol.-% CO ₂	<i>Standard</i> CLD 824 MM dr	dual sample gas inlet, two metal converter and electro-mechanical pressure regulation
<i>Sample flow rate</i>	1.2 l/min (0.2 l/min resp. 0.05 l/min without option r)	<i>Options</i>	S steel converter h hot tubing
<i>Input pressure</i>	600–1200 mbar abs. (without option r to be externally stabilized within ± 3 mbar)		
<i>Dry air use for O₃ generator</i>	internally generated (no external supply gas required)		

* depending on filter setting

ECO PHYSICS reserves the right to change these specifications without notice.

Flow diagram

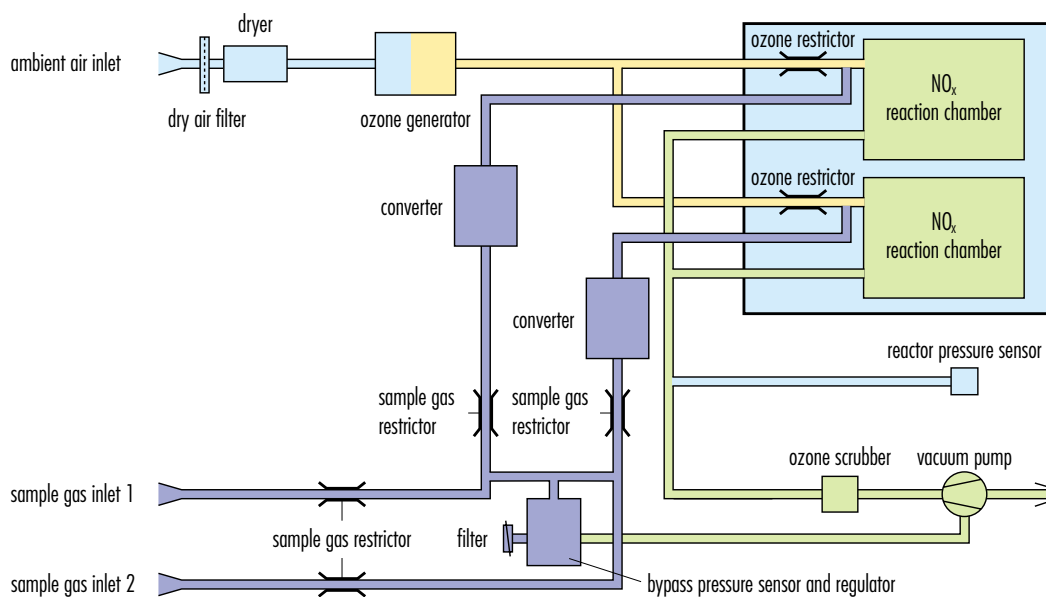

ECO PHYSICS