

ECO PHYSICS CLD 86

Application examples



- Ambient monitoring in areas with excellent air quality
- Supervision of production processes in the chemical and high technology industries
- Permanent monitoring of clean room conditions in R & D labs
- Biomedical and pharmaceutical research
- Plant physiological research

The CLD 86 nitrogen oxide analyzer is unique in its speed and precision. It makes possible the continuous measurement of NO concentrations even in the range of parts per trillion!



Clean room laboratories require reliable and precise gas analysis.

When decimals are decisive.

The CLD 86 fulfills the requirements of many research laboratories specializing in detecting and monitoring smallest variations of NO concentrations in less than a second despite its total sample flow. The lagtime of less than a second makes it even more attractive.

NO_x is measured by an optional molybdenum converter. Unwanted effects of long sampling lines are minimized by the electronic and mechanical bypass system (option r).

User friendliness.

The development of an ECO PHYSICS analyzer always includes full user comfort. The user can adapt the operation according to his needs and applications by selection of predefined settings.

Warning messages or malfunctions are displayed coded and in full text. The analyzer guides the user step by step to return to normal operation.

The use of first-rate components guarantees virtually service-free operation. Maintenance simply means annual replacement of filters and membranes besides the consumables required by special sampling conditions.

Unique calibration by pressing a button!

The accuracy of chemiluminescence detection is strongly dependent on the calibration of the analyzer.

In order to assure reliability of its results the CLD 86 analyzer has optionally a calibration module (l) for the zero level and the NO reference gas. Calibration is quickly and automatically carried out by pressing a button on the keypad. This extremely useful feature eliminates the potential risk of erroneous calibrations.

Compact and modular construction.

The CLD 86 is the most compact unit of its class. Thanks to the totally modular layout and the rich variety of options this analyzer is designed for a multitude of applications.

- Compact design without any additional space required
- Optional molybdenum converter for NO_x detection
- Four freely selectable measurement ranges
- Operation and control via keypad or personal computer
- Optional bypass system to increase the sample flow
- Rapid system integration
- Optional calibration module for zero level and span gas calibration.

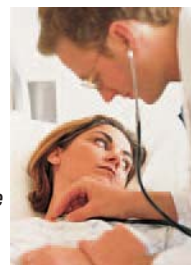

NO_x Range SHBL
39.32 100.0 PPB

Meas. Mode Recorder Autocal MENU
Date/Time Comp. Timers Filter

Time for Calibration: 10.0 (s) MENU
NO-Cylinder Conc.: 100.0 (ppm)

Stand-by (Y/NERS)?
Zero Pressure out of Range N-02

Clearly structured and full text displays inform the user about the instrument's status, any errors and measures to return to normal operation.

CLD 86

Specifications

Measuring ranges	four freely selectable ranges from 50-50000 ppb	Analog output	4-20 mA into 500 Ω max.; 0-1 V; 0-10 V
Min. detectable concentration	0.5 ppb*	Dimensions	height: 133 mm (5 1/4 ") width: 450 mm (19 ") with moulding: 495 mm depth: 545 mm
Noise at zero point (1 σ)	0.25 ppb*	Weight	24 kg
Lagtime	<1 sec	Delivery includes	CLD 86 analyzer, power cable, analog signal cable, manual
Rise time (0-90%)	<1 sec	Standard	CLD 86 NO analyzer
Temperature range	5-40 °C	Options	Y molybdenum converter I automatic calibration module for zero level and span reference gas or r electro-mechanical pressure regulation
Humidity tolerance	5-95% rel. h (non-condensing, ambient air and sample gas)	* depending on filter setting	
Sample flow rate	0.1 l/min (1.2 l/min with option r)	ECO PHYSICS reserves the right to change these specifications without notice.	
Input pressure	ambient		
Dry air use for O ₃ generator	internally generated (no external supply gas required)		
Power required	400 VA (incl. membrane pump and ozone scrubber)		
Supply voltage	100-230 V/50-60 Hz		
Interface	RS 232		

Flow diagram

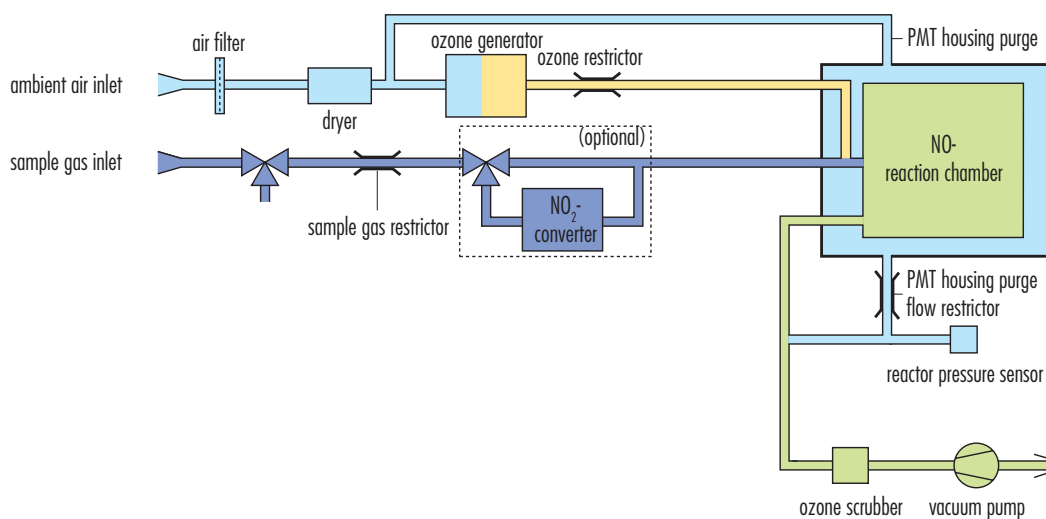

ECO PHYSICS

ECO PHYSICS, INC. 3915 Research Park Dr. A-3 Ann Arbor, MI 48108 tel. 734-998-1600 fax 734-998-1180
Email: sales@ecophysics-us.com Website: <http://www.ecophysics-us.com>